

Chip breaking phenomenon during cutting steel and polymer materials

János Liska¹

¹John Von Neumann University, GAMF Faculty of Engineering and Computer Science, Kecskemét H-6000, Izsáki út 10, e-mail: liska.janos@gamf.uni-neumann.hu

Article history

Received 30.06.2017
Accepted 15.09.2017
Available online 30.10.2017

Keywords

Cutting forces
Cutting temperature
High Speed Camera
Polymer
Turning

Abstract

Research in 60s and 70s started to deal with the shape of the chip characterization. It was possible then to do a limited study by means of measuring tool park. During such a study, different models for chip formation became familiar, such as the Time or Merchant model. The aim of article is to gain insight into some accompanying phenomena, occurring while cutting of different materials and with various tools. During an experimental design, the possible effects of different variables on each other and individually were considered. Two work-pieces (C45, POM) with two inserts (with two different edge design) were tested while changing of cutting speed and feed. During measurements cutting forces at 5000 Hz signal reception were tested or the evolution of cutting temperature at different experimental settings was evaluated. The chip characteristics are measured by a high speed camera. The camera is connected with PC for recording and controlling the experimental procedure in real-time. The frequency of High Speed Camera was similar than the frequency of the cutting force measuring system. This similarity is provided with the system set-up synchronization.

1. Introduction

A chip flow in all wedged-tool machining processes can be described, in theory, in a common way, by means of two different cutting schemes termed orthogonal cutting. In orthogonal cutting (Fig. 1) a cutting edge of the tool is perpendicular to the direction of relative work-piece cutting tool motion and also to the side face of the work-piece. From the relative movement of work-piece and cutting tool, a layer of material in the form of chip is removed. In order to continue removing the material in the second stage, the tool is taken back to its starting position and fed downwards by the amount f , the feed of the process. Perpendicular to f , h is the depth of cut, which is smaller than or equal to the width of the tool edge. The surface along which the chip flows is the rake face of the tool. The angle between the rake face and a line perpendicular to the machined surface is called rake angle β . The face of the tool that is near the machined surface of the work-piece is the flank face. The angle between the flank face of the tool and the work-piece is called clearance angle α . The angle between the rake face and the flank face is the wedge angle γ . The sum of the three angles is always equal to 90° , thus:

$$\alpha + \beta + \gamma = 90^\circ \quad (1)$$

Orthogonal cutting represents a two-dimensional mechanical problem with no side curling of the chip considered. It represents only a small fragment of machining processes, i.e. planing or end turning of a thin-walled tube. However, it is widely used in theoretical and experimental work due to its simplicity. Because of its 2D nature many independent variables are eliminated, e.g. two cutting forces are only identified to orthogonal cutting problems. (MARKOPOULOS A.P. 2013).

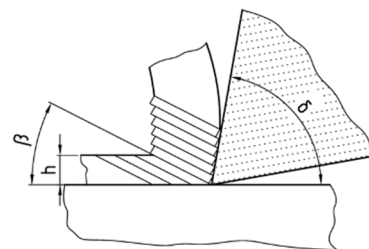

Fig. 1. Merchant model of orthogonal cutting
Source: BUDA J., BÉKÉS J. 1977

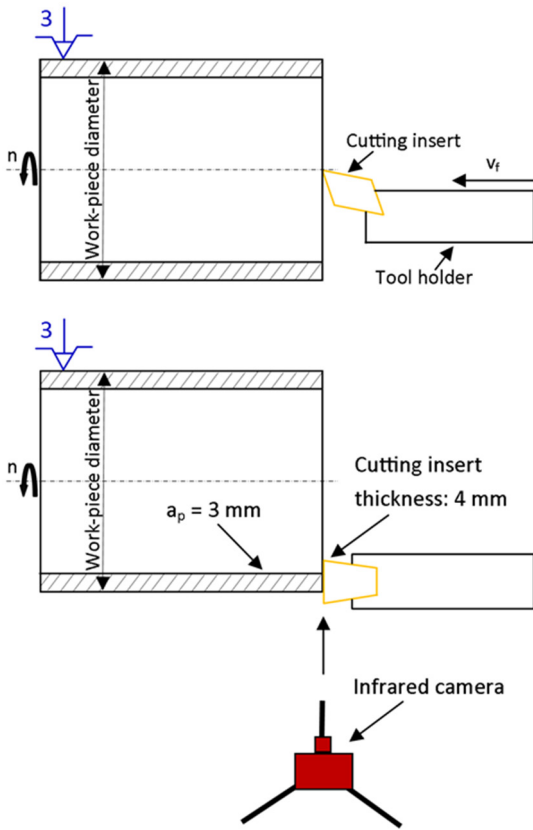

Fig. 2. Experimental set-up

2. Design of Experiments

Experiments in mechanical engineering are planned by the help of full-factorial design of experiment, which states; that for investigation of machining process the “black box” is applicable (Fig. 3). The outgoing arrow on the right side is the dependent variable, which is marked as \hat{y} . The value of the dependent variable has to be impressible. The influencing factors are referred as independent variables (factors) and are marked as X_i . The black box can have more \hat{y}_i outputs. Factors can include more values, these values are levels. The experimental settings can be created by the combination of factor levels. These settings are variable values of \hat{y} . In the so called active experiments all factors were set on 2 or 3 level and their values were changed in a predetermined order. This method ensures reliable variations with limited settings (LÍSKA J., GÁL B. 2013).

An experiment with combination of four variables of minimum and maximum values was designed. The variables are:

- cutting speed v_c ; ($v_{cmin} = 100$ m/min; $v_{cmax} = 150$ m/min),
- feed f ; ($f_{min} = 0.05$ mm/rev.; $f_{max} = 0.1$ mm/rev.),
- work-piece material; (C45; POM.),
- Cutting inserts: (I.; II.)

The inserts are:

- I. Sandvik Coromant QD – NH – 0400 – 0004 – TF 1125

- II. Sandvik Coromant QD – NH – 0400 – 0004 – TM 1125

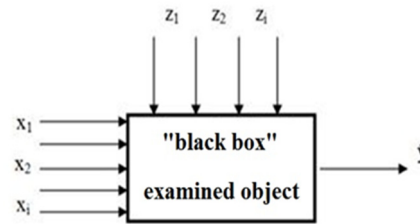

Fig. 3. Basics of Experimental Design

Source: LÍSKA J., GÁL B. 2013

The forces at machining by dynamometer KISTLER 625 7/B were measured. An infrared camera Flir T360 and High Speed Camera Olympus for the high speed pictures were also used. The zone of machining from distance 800mm (Fig. 2) was observed. The work-piece was a C45 steel and POM (polioximethilen) in diameters 101mm and 135mm. Both inserts (Fig. 4) was PVD coat (Ti,Cr,Al)N+(Ti,Al)N. The cutting inserts of different geometry can be seen in fig. 3.-It is also noticeable that the chip breakers are different.

During the DOE (Design of Experiments) the statistical software MINITAB was used. An experimental table was generated by means of software after inputting the primary data.



Fig. 4. Cutting inserts a) - Tool I, b) -Tool II.

Source: SANDVIK COROMANT

3. Results and discussion

The measurement of tool geometry is very important during the experiments. Besides two different tools, a contour and surface measurement system was used for measuring the cutting tool geometry (Fig. 5).

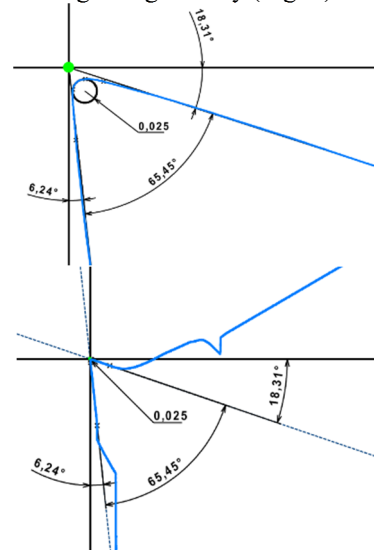

Fig. 5. Tool geometries

Before the cutting force measurements, the measurement goodness was supposed to be checked. In Fig.6 the evaluation of main cutting forces without cutting can be seen. At the beginning it can be observed that the forces are very closed to zero (the small tail swing is only the error of the measurement card of dynamometer). After turning on the spindle clearly shows relatively higher tail swing. If the spindle is turned off, the forces are similar to those at the initial phase of the measurement.

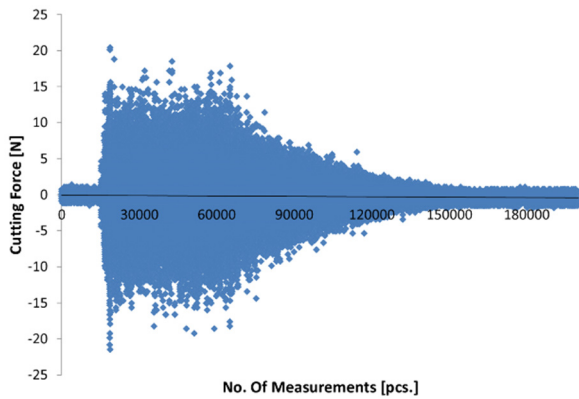

Fig. 6. Checking of measurement goodness

After checking the accuracy, the main cutting forces were measured. For better understanding, one measurement can be presented as an example. The work-piece material was C45, the cutting tool material was no. II, and the cutting parameters were: $v_c = 100$ m/min, $f = 0,1$ mm/rev. In the Fig. 7, the evaluation of main cutting forces can be observed. The diagram clearly shows; that two different type of results occur:

- the indent area of cutting forces
- the area of cutting forces

The attribution of the curve is a standard.

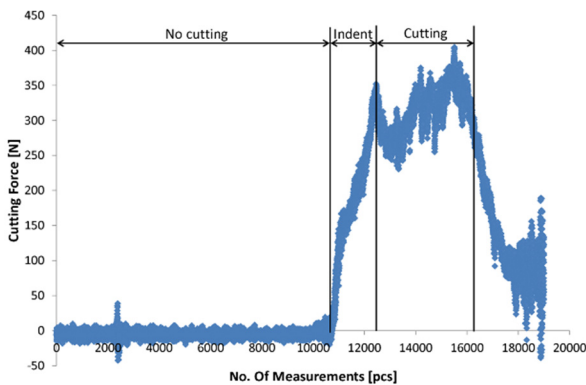

Fig. 7. Evaluation of main cutting forces

However, the closer the indent is, the more interesting phenomena can be observed. In Fig. 8 a very fast area of cutting can be seen. The duration time was only 0.17 s. This small area is not characteristic for the exponential trend. The best trend line was 5th degree polinom. On the diagram it can be noticed that curve in the middle part was gently sloping which happened because, owing to cutting temperature, the

turning of work-piece was light cutter. After few milliseconds the cutting temperature increased faster.

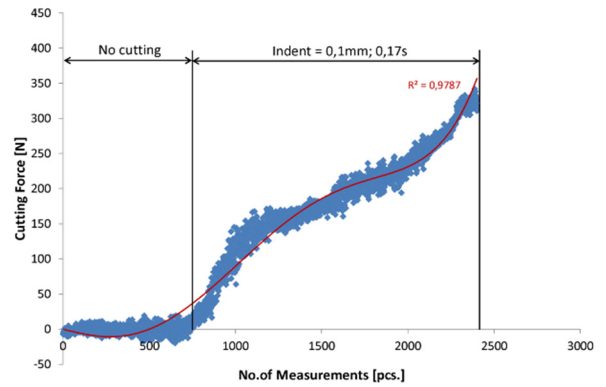

Fig. 8. Evaluation of indent of the tool to the work-piece

The third diagram (Fig. 9) shows the first contact area of the tool with the work-piece. It is a very fast area (it is around 26 ms), and 210 measured points for better results were obtained. The trend of the curve was very similar to the one in Fig. 6, but here the slop was not very gentle. Moreover, the accuracy of a curve was evaluated. It was about 82%, which is a very good value for such a fast area.

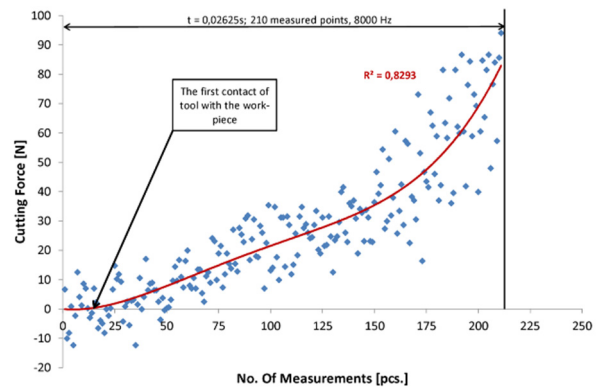

Fig. 9. The first contact of the tool with the work-piece

The characteristic areas; which can be seen in Fig. 6, are also shown in Fig. 10. The picture; presents the evaluation of cutting temperature at the indent area. Firstly (on the left), it can be observed that the chip has no colour. Later, however, if looked at from the left to the right, one can notice different colours; yellow, brown and purple.



Fig. 10. Chip coloured due to cutting temperature

The results are shown in 2D diagram (but the results which could be seen on the diagrams was three-dimensional – F_c , f , v_c), in Figure 11-18. Main cutting forces (F_c) were formed by the known professional literature at material C45. By increasing of feed (f) the chip cross section and forces also increases. Therefore, while increasing cutting speed (v_c), a small decrease is detected. The cutting temperature is established similarly, like in the literature. It varies in using the II. tool, where cutting temperature increased greatly with increasing of cross section.

Due to the chip breaker of II. tool which has another design, the chip goes longer section on the insert. Therefore, it will have a higher friction. It confirms temperature recordings. Forces were inversely proportional as compared to C45, at material POM. This is because the material has a worse thermal conductivity. The material softens quickly and energy of chip removal will be smaller. It shows itself at evolution of cutting temperatures, too. In this case higher feed and lower cutting speed has a better impact at using of II. tool. It means, that higher technological parameters had a beneficial impact on cutting temperature. It also resulted in forces, which decreased at using of bigger parameters. It has a positive impact on the economy of cutting. Supervising of critical cutting temperature (which is different in all materials), because if it reaches this temperature at plastics, it can result in damage of material.

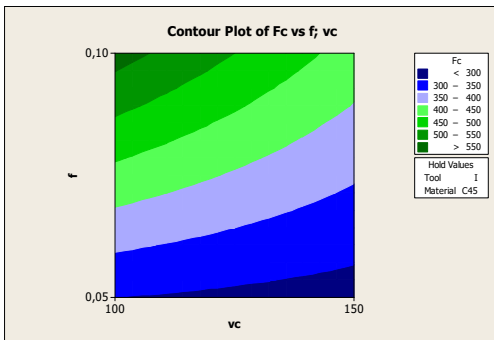

Fig. 11. Main cutting force (F_c) evaluation with two variables (f and v_c) at machining C45 material and Tool I.

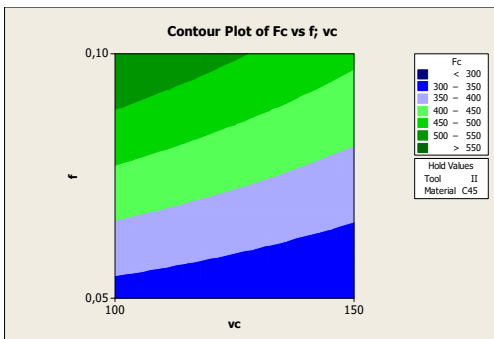

Fig. 12. Main cutting force (F_c) evaluation with two variables (f and v_c) at machining C45 material and Tool II.

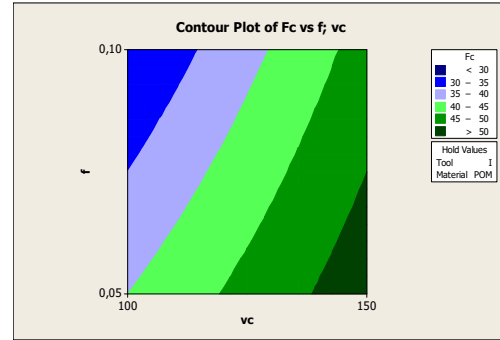

Fig. 13. Main cutting force (F_c) evaluation with two variables (f and v_c) at machining POM material and Tool I.

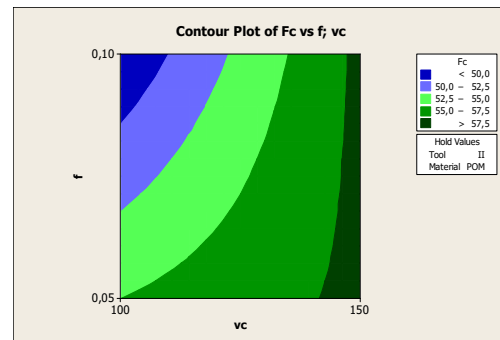

Fig. 14. Main cutting force (F_c) evaluation with two variables (f and v_c) at machining POM material and Tool II.

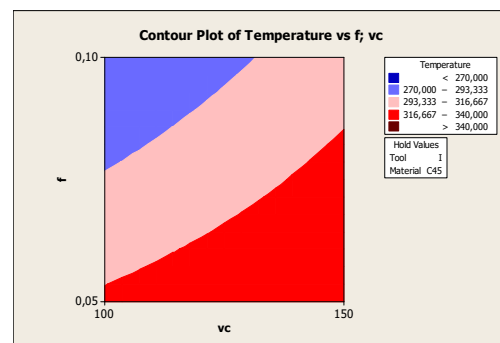

Fig. 15. Cutting temperature evaluation with two variables (f and v_c) at machining C45 material and Tool I.

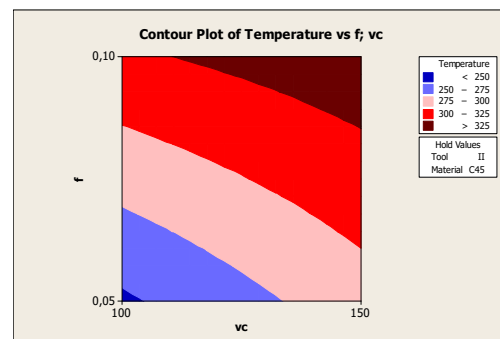

Fig. 16. Cutting temperature evaluation with two variables (f and v_c) at machining C45 material and Tool II.

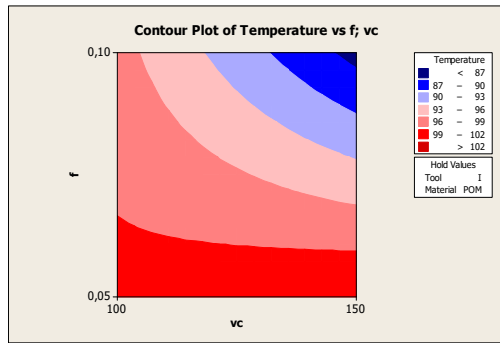

Fig. 17. Cutting temperature evaluation with two variables (f and vc) at machining POM material and Tool I.

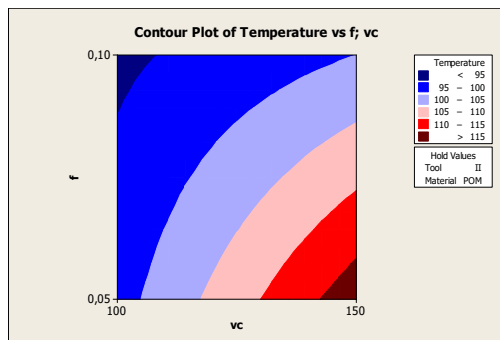

Fig. 18. Cutting temperature evaluation with two variables (f and vc) at machining POM material and Tool II.

During the measurement the High Speed Camera (HSC) system can be used. The base of HSC in this article was a better understanding of the indent area zone. Fig. 8 shows the indent area and its size. On the other hand, there were four different zones in the indent area, which can be seen in Fig. 19. The first was the first contact of the tool with the work-piece (Fig. 20). After that, in the second zone there is no cutting area, this is the plastic deformation – burnishing zone (Fig. 21). In Fig. 22 the half cutting area can be seen, which can represent of the transition from the deformation zone to the cutting zone. At the end, in Fig. 23 the area where the tool is working with full chip area can be seen.

Fig. 20-23 presents cutting polymer material. While cutting steel similar situations and indent area zones occur.

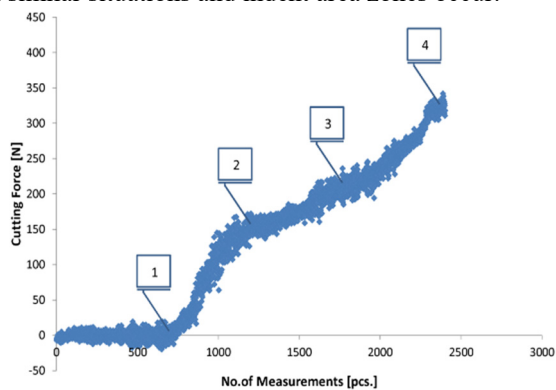

Fig. 19. The indent are zones

At the time of the first contact, the material has a significant resistance at the front of the tool. This area was

also uncertain, and here was the biggest prospect of the tool crash.

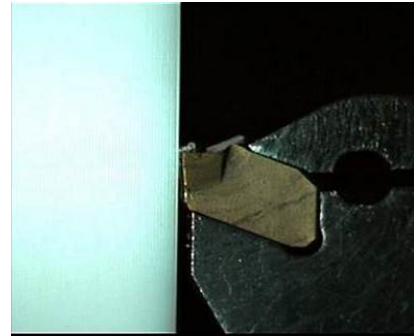

Fig. 20. First contact of the tool with the work-piece

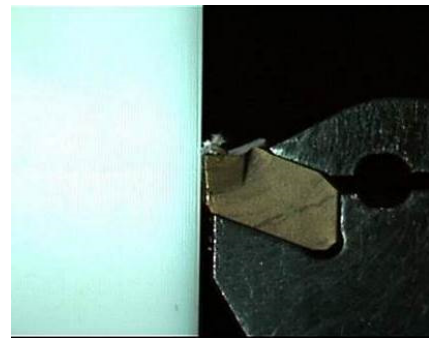

Fig. 21. No cutting zone

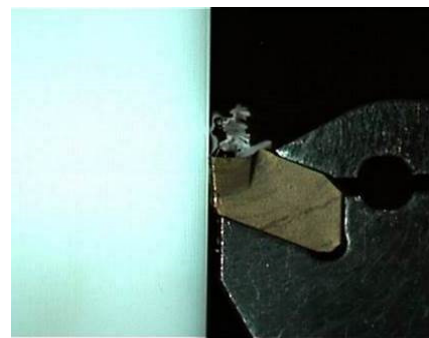

Fig. 22. Half cutting zone



Fig. 23. Cutting zone

In the second zone we have burnishing occurs. Fig. 19 we shows a significant increase of the force from point 1 to 2, which is typical for this area. Consequently, the cutting temperatures also increased here.

After the increase of force and cutting temperature gently sloped area occurs. Here, the material was “softer” and the cutting is easier than in the case of the previous part.

Finally, in the fourth zone there is a full chip area cutting zone, and here the cutting force reaches the maximum value. From this point the forces did not increase, it rather stagnated around a value. This area is called cutting zone, and values from this sector we can be used for standard evaluations.

In every experiments, it is very important to obtain effect of the cutting parameters and their response to attendants. In this article, the MINITAB statistical software can be used. With the help of this software, the full factorial experiments were planned, and some crucial things were also evaluated. Fig. 24-25 present the Pareto charts of the main effects. Firstly, the main effects of cutting forces.

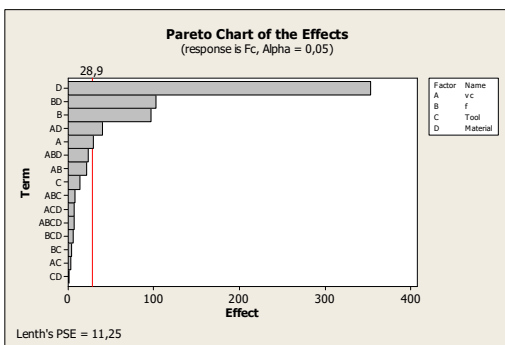

Fig. 24 Pareto chart of main cutting force

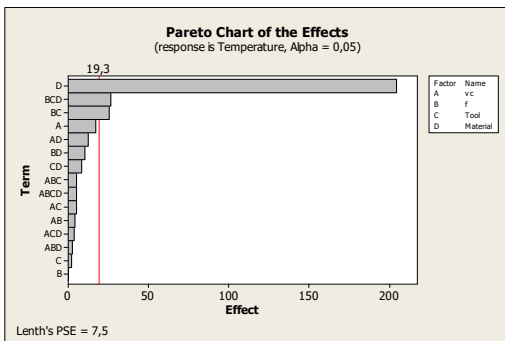

Fig. 25. Pareto chart of cutting temperature

The chart clearly shows the main effect was the material, feed-material, feed and cutting speed-material. It was very interesting, because if the material is left, the main effect was the feed and cutting speed, and the feed had a bigger effect (one of the chip area factor) than the cutting speed. Fig. 25 shows a similar situation, but there is an additional effect, i.e., the tool. Therefore, it can be definitely stated that the tool and its conductivity have a big impact on the evaluation of cutting temperatures.

4. Summary and conclusion

This article is an introduction to the research of chip removal mechanism. The goal is to explore chip removal mechanism of more plastic or composite material. Modern statistical software of today and different simulation software and measuring tools aid in exploring of never phenomena and mechanisms.

In the future, the experiment has been planned to be repeated with the use of other materials, tools, or cutting parameters.

Acknowledgements

This research is supported by EFOP-3.6.1-16-2016-00014 project. The Project is supported by the Hungarian Government and co-financed by the European Social Fund.

Reference

AVAILABLE ON: <http://www.sandvik.coromant.com/engb/products/pages/productdetails.aspx?c=QD-NH-0400-0004TF%201125#query=%7B%22n%22:%22Insert%22,%22I%22:%22%22,%22r%22:%22%5B%5D,%22c%22:%22%5>

BUDA J., I BÉKÉS J. 1977. *Teoretické základy obrábání kovov*. Alfa, Bratislava.

AZVAR M., BUDAK E. 2017. *Multi-dimensional chatter stability for enhanced productivity in different parallel turning strategies*, In International Journal of Machine Tools and Manufacture, Volume 123, 116-128.

LÍSKA J., GÁL B. 2013. *Turning of Composites*. Factory Automation, Veszprém, 79-82.

MARKOPOULOS A.P. 2013. *Finite element methods in manufacturing processes*. Softcover, 14-15.

切割钢和聚合物材料时的切屑现象

关键词

切割力
切割温度
高速相机
聚合物
车削

抽象

60年代和70年代的研究开始处理芯片特性的形状。然后通过测量工具园进行有限的研究。在这样的研究中，不同的芯片形成模型变得很熟悉，例如Time或Merchant模型。文章的目的是深入了解一些伴随的现象，同时切割不同的材料和各种工具。在实验设计中，考虑了不同变量对于每个变量的可能影响。在改变切割速度和进给的同时，测试了具有两个刀片（两个不同边缘设计）的两个工件（C45，POM）。在测量期间，测试了在5000Hz信号接收处的切割力，或者评估了不同实验设置下切割温度的演变。芯片特性由高速摄像机测量。相机与PC连接，用于实时记录和控制实验程序。高速摄像机的频率与切割力测量系统的频率相似。系统设置同步提供了这种相似性。